

ENERGY WORKS
SOLAR HOT WATER HEATERS
OPEN LOOP SYSTEMS
INSTALLATION MANUAL

CONTENTS

Introduction	1
Basic Tools and Materials	1
1. Collector Location	2
2. Collector Orientation	2
3. Collector Dimensions	3
4. Mounting Hardware	4
5. Mounting Hardware Spacing	7
6. Pitch Pan	7
7. Array Mounting	8
8. Collector Piping	9
9. Collector Piping Detail	9
10. Sensor Mounting at Collector	10
11. Piping through Roof	10
12. Storage Tank Placement	10
13. Sensor Mounting at Storage Tank	11
14. Open Loop Fluid Handling System	11
15. Open Loop Differential Temperature Controller	12
16. Open Loop Start-Up	13
17. Open Loop Maintenance	13
18. Direct PV System	14
19. Operational Checklist	15
Systems Parts List	16
Collector Yard Mount	16

INTRODUCTION

Years of research and development backed by critical engineering have brought you the finest solar products you can buy. Please take time to read this booklet thoroughly. Diagrams illustrate where necessary.

With a little thought and careful planning, your system can be installed quickly and easily by yourself or by a qualified plumber with a minimum of disruption to your business or home.

BASIC TOOLS AND MATERIALS

Electric Drill	Adjustable Wrenches 8" & 10"
Drill Index (w/ 1/2" and 3/4" Wood Bits)	Torch and Striker
Hack Saw	100 PSI Pressure Gage
Tubing Cutter	Putty Knife
Tin Snips	High Temperature Pipe Joint Compound
16' Tape Measure	Wire Nuts or Connectors
24" Level	Miscellaneous Copper Pipe & Fittings (3/4")
Flashlight	Solder Flux
Extension Cord	Emory Paper
Slip Joint Pliers	Silicon Caulk and Roof Tar
Needle Nose Pliers	1/2" I.D. Copper Tubing & Installation
Pipe Wrenches, 10" & 14"	Angle Iron
Open End Wrenches, 9/16 & 7/16	Threaded Rod, Nuts, & Washers
Screw Driver 6" Flat Blade	Stainless Screw Clamps
Screw Driver 6" Philips	Thermal Adhesive
Wire Stripper or Knife	Aluminum Flashing Sheet
Wire Cutters	

1. COLLECTOR LOCATION

Proper location and orientation of the solar collectors is important for maximum system efficiency. The collectors should be no shaded for the middle six hours of the day in each month of the year and should be located as close to the storage tank as possible to minimize heat loss in the piping runs. The best orientation is achieved

when the collectors are facing due south and tilted at an angle from the horizontal of latitude + 10°. Figure 1 below shows many alternatives for collector mounting. When roof mounting, place the collectors as close as possible to the peak of the roof will make installation easier due to increased attic access.

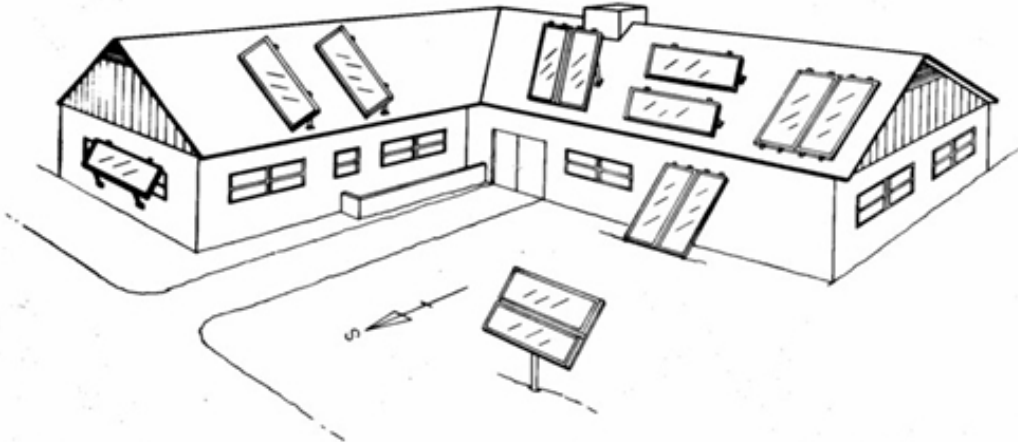

Figure 1

2. COLLECTOR ORIENTATION

Proper tilt angle for solar collectors is latitude plus 10° (see latitude map). This favors the winter sun because ambient temperatures are lower during the winter and collector efficiency suffers. This 10° additional tilt equalizes year round performance. Spacing can be determined from Table 1.

When collectors are mounted one behind the other, they are spaced apart so that in the morning and afternoon on December 21, when the sun is at its lowest altitude, the collectors will not shade each other and cause efficiency loss.

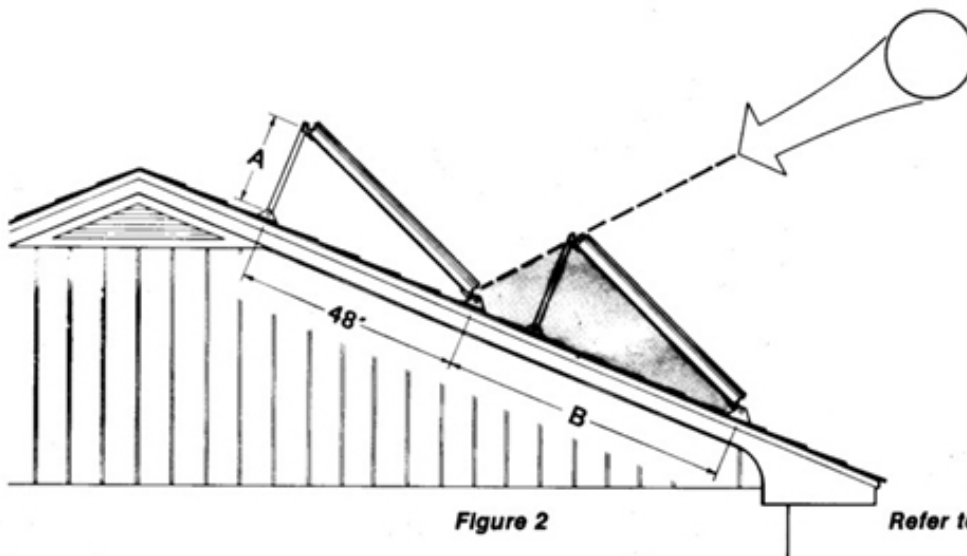

Figure 2

Refer to Table 1

LATITUDE		25° N		30° N		35° N		40° N		45° N		50° N	
COLLECTOR TILT		35°		40°		45°		50°		55°		60°	
		A	B	A	B	A	B	A	B	A	B	A	B
ROOF PITCH	FLAT	29	96	33	113	37	145	41	145	44	145	48	145
	5° 1/12	25	83	29	93	33	113	37	132	41	133	44	141
	9° 2/12	22	74	26	82	30	77	34	110	38	115	41	118
	14° 3/12	17	66	22	72	26	82	30	92	34	95	38	98
	18° 4/12	14	61	18	66	22	74	26	81	30	85	34	87
	23° 5/12	10	58	14	60	18	66	22	72	26	74	30	77
	27° 6/12	7	58	11	58	15	61	19	66	23	68	27	70
	30° 7/12	4	58	8	58	13	58	17	58	21	58	25	58
	34° 8/12	0	58	5	58	9	58	13	58	17	58	22	58
	37° 9/12	-2	58	3	58	7	58	11	58	15	58	19	58
	40° 10/12	-4	58	0	58	4	58	8	58	13	58	17	58
	43° 11/12	-7	58	-3	58	-2	58	6	58	10	58	14	58
	45° 12/12	-8	58	-4	58	0	58	4	58	8	58	13	58
VERTICAL		-44		-41		-37		-33		-29		-25	

Table 1. All Lengths in inches

3. COLLECTOR DIMENSIONS

Collector	Gross Area (ft ²)	Dimensions (in)	Transparent Area (ft ²)	Weight (lb)
AE-21	20.87	35 3/16 x 85 3/16	19.22	74
AE-24	23.81	35 3/16 x 97 3/16	21.99	84
AE-26	25.35	47 3/16 x 77 3/16	23.65	90
AE-28	27.97	47 3/16 x 85 3/16	26.16	99
AE-32	31.91	47 3/16 x 97 3/16	29.93	113
AE-40	39.79	47 3/16 x 121 3/16	37.47	153

Tested: TUV (DIN 4757, RAPPERSWILL, ONORM M7714, FSEC, SRCC, Metropolitan Dade County, Miami Test Lab

Table 2. Collector Dimensions

MOUNTING HARDWARE

Provided in the package is specially designed mounting hardware to speed collector installation. This hardware consists of four LOCK-TIGHT hinge sets, four roof brackets; two rears strut, and bolt (Figures 3, 4, and 5).

- (a) After locating the mounting points from Table 1, the mounting bracket holes should be drilled.
- (b) A heavy coating of sealant should be applied to the bottom of the flashing plate, which should fit flat against the roof. It is necessary for the plate to slide under the above shingles to insure proper drainage of water.
- (c) The bottom of the roof bracket and the area around the threaded rod should also be thoroughly coated with tar sealant. When the bracket is set in place, alignment with the collector hinges is necessary before final tightening of the nuts. This should be completed before the sealant has time to set.
- (d) The threaded rod is fastened through a 2' x 6" wood or 2" x 2" x 1/4" steel angle bracket under the roof as shown.
- (e) The rear struts should be cut and drilled to conform to Table 1. All bolts should be

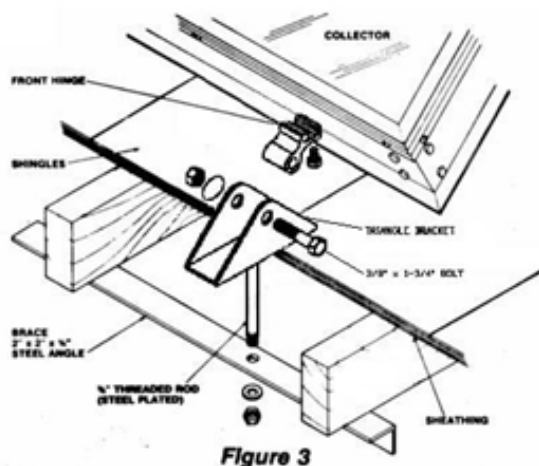

Figure 3

There are three acceptable ways to secure the collector mounting brackets to the roof. 1. Spanner Mounting

2. Lag Bolt Mounting
3. J-Bolt Mounting

In spanner mounting after the brackets are positioned on the chalk line, a 3/8" hole is drilled between the rafters. Aluminum flashing is positioned over the hole where the top of the flashing is extended up under the shingle above the 3/8" hole and extends down over it. Caulk is applied between the flashing and the roof. The bracket is then positioned over

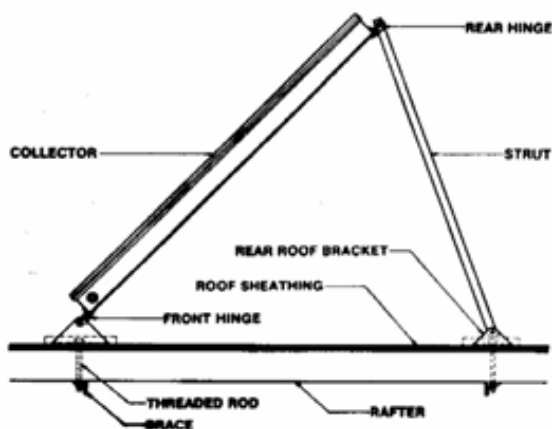

Figure 4

tightened securely. A stainless steel washer should be placed where the threaded rod passes through the aluminum bracket. It is very important that the penetrations through the roof be well sealed. It should be carefully checked that all bolts are coated with tar and that no leaks are possible.

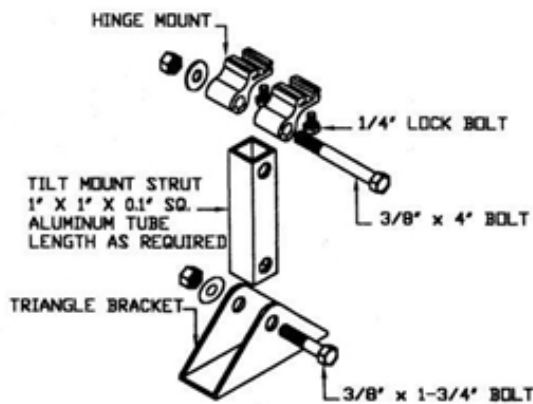

FIGURE 5

the 3/8" hole using sealant between the bracket and the flashing. A piece of 3/8" all-thread is then inserted through the hole. A washer and nut secures the all-thread to the bracket (be sure the seal underneath the washer and on top of the nut). The all-thread rod should extend about 4" below the roof rafters. Drill a 3/8" hole in a 2 x 4 and insert the all-thread rod through it. The 2 x 4 should span 2 rafters. With a washer and double bolt secure the all-thread to the 2 x 4. Tighten down until the bracket is tightly secured to the roof. Be careful not to over-tighten and bell out the roof underneath the bracket. (See Figure 6)

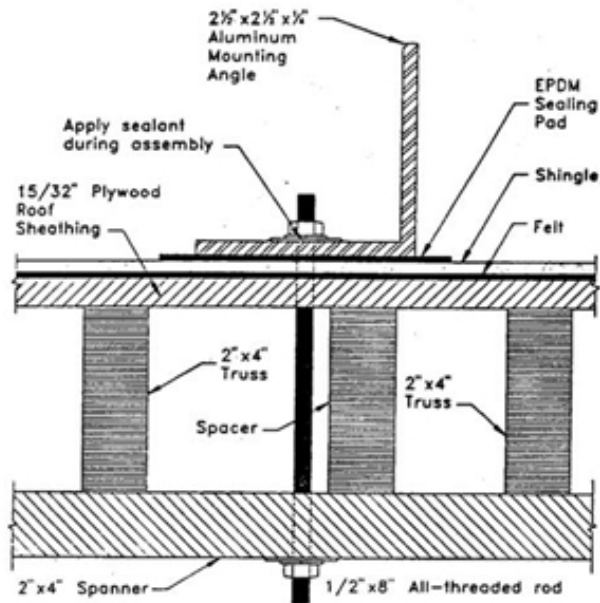

Figure 6. Spanner Mounting

In lag bolt mounting you must locate the center of the rafters along the top and bottom chalk lines. One method is to have one man on the roof and another in the attic. Using a hammer the man on the roof can tap the roof and determine where it is denser sounding. The roof man can drill a pilot hole while the attic man helps with distance corrections.

Then the attic man can call off the distance to the next rafter while the roof man drills corresponding pilot holes. Flashing the brackets is done as previously described. Secure the brackets to the roof using a 1/4" x 3" stainless lag screw, a flat washer, and a lock washer (Figure 7).

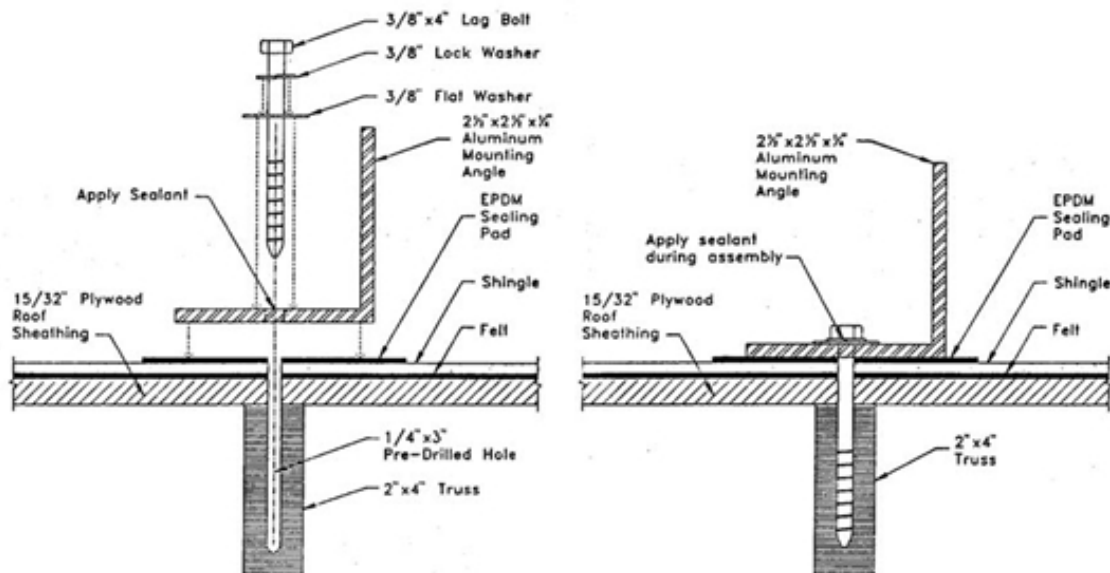

Figure 7. Lag Bolt Mounting

J-bolt mounting is done very similar to lag screw mounting except instead of drilling into the center of a rafter, a hole must be drilled directly beside a rafter. The size of the hole must be slightly larger than the bolt diameter. This is more easily accomplished if the attic man would drill a pilot hole through the roof along side the chosen rafter.

Fit the bolt through the mounting brackets and insert the bolt (J side first) through the hole in the roof. Work the J underneath the rafter. Pull the J-bolt snug against the rafter before tightening the nut. Use double nuts or lock-washers to securely fasten the mounting bracket to the J-bolt (Figure 8).

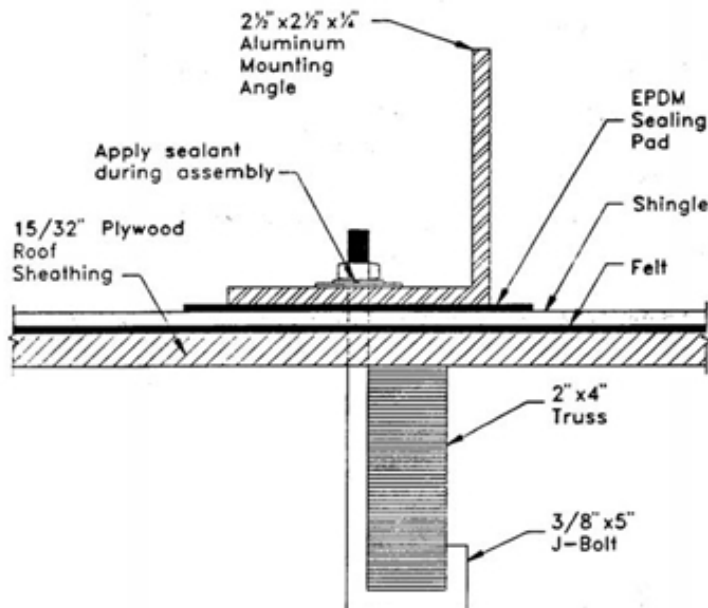

Figure 8. J-Bolt Mounting

4. MOUNTING HARDWARE SPACING

Follow the span and spacing indicated as per instructions provided with the equipment.

5. PITCH PAN

The pitch pan is necessary any time standing water is encountered (Figure 9).

The purpose is to provide an adequate seal around any penetration in the roof.

- (a) The pitch pan is placed in the proper position and flat on the roof.
- (b) Its flange is sealed with roofing felt and hot tar.
- (c) The holes are sealed on the inside with roofing tar to a sufficient level to insure a permanent seal.

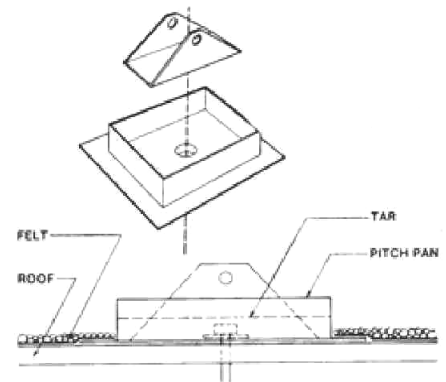

Figure 9

6. ARRAY MOUNTING ON TILE ROOFS

Tile roofs are a little more difficult to mount solar collectors on but following this procedure will render a leak free installation.

The solar panels are mounted on two rails located at the top and bottom of the solar collectors. The collectors are secured to the rails using the rack mount hardware. The 1 5/8" Aluminum unistrut rails are anchored to the roof by using six or ten inch stainless steel 3/8" hanger bolts. These bolts are lag screw on the bottom and 3/8 NPT thread on the top. A ten foot length of unistrut should be anchored at three points, the middle and both ends.

Procedure

- Cut 12" x 12" square pieces of lead flashing.
- Locate the roof rafters beneath the tile where the hanger bolts will be attached. Drill a 3/8" hole through the tile.
- Slide the 12" x 12" lead flashing under the tile located above the 3/8" hole, then drill through the lead flashing into the hole.

- Screw lag portion of the 3/8" hanger bolt into the rafter.
- Cut strips of the lead flashing about 1 1/2" long and wide enough that when you fold it into a tube is slightly larger in diameter as the hanger bolt.
- Using an acid core solder, weld the seam of the tube together.
- Slip this tube over the top of the hanger bolt protruding from the roof, then solder it to the 12" x 12" lead flashing.
- Thread down a stainless 3/8" nut to the bottom of the thread and seal the top of lead tube to the nut with a polybutalene caulk. Slip a 3/8" stainless washer on top of the nut.
- Place the 1 5/8" aluminum rail on the hanger bolt and secure with another 3/8" stainless washer and nut.

The rail is now secured, weather tight to the tile roof. Next, mount the solar collector to the rail using the rack mounts. See Figure 10.

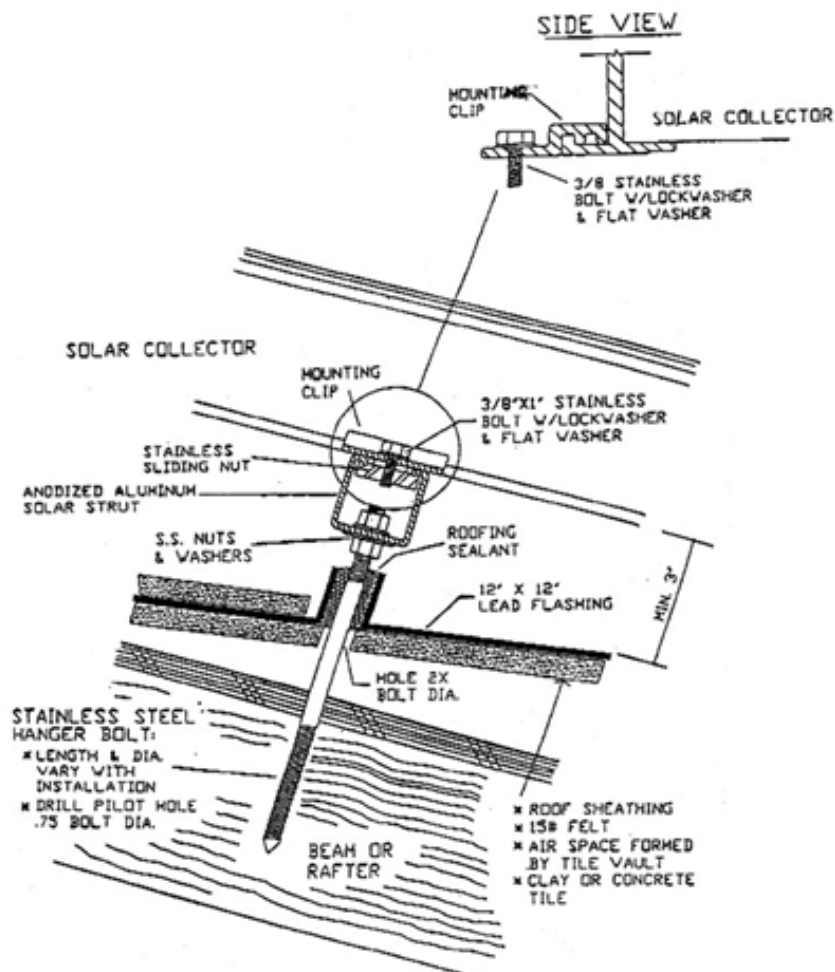

Figure 10

7. COLLECTOR PIPING

The piping of the system should be considered before a final decision is made on how the collectors are mounted. Piping should be made of copper tube of the type meeting local codes, insulated and painted or wrapped with aluminum tape where exposed to ultraviolet radiation.

Care should be taken in the spacing of collectors as attachment of piping is easiest with properly aligned collectors. The collectors and piping to the storage tank should be slightly sloped downward (3" in 8 feet) to allow draining in case of freezing conditions. Soldered connections should be made with 95/5 solder.

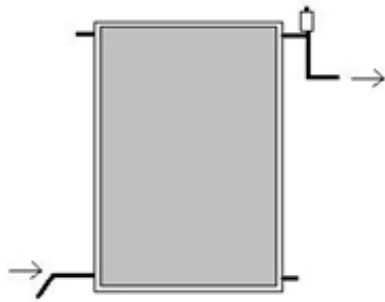

Figure 11

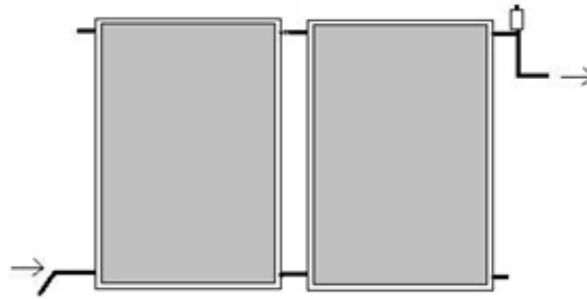

Figure 12

8. COLLECTOR PIPING DETAIL

The outlets of the collector are 1" copper pipe nipples (Figure 13). They should be piped as shown with provisions for an automatic air vent. This will prevent air lock and subsequent loss of system efficiency. The copper union makes attachment of piping to collector easy. Teflon tape or high temperature, high quality pipe sealant should be used when making threaded connections. The collector inlets should be piped similarly but without the automatic air vent.

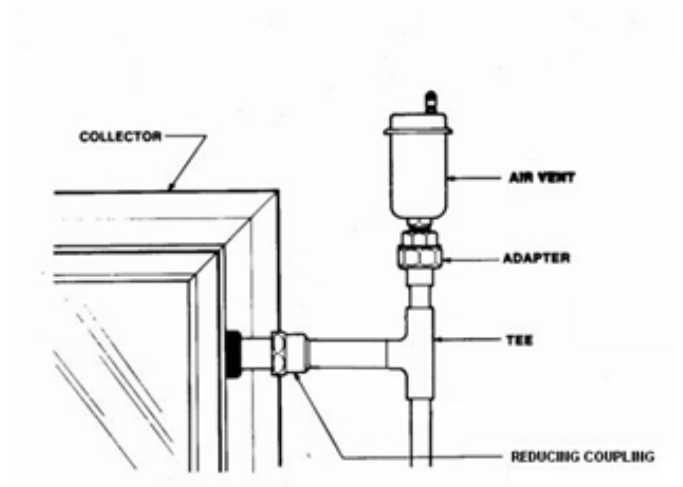

Figure 13

9. SENSOR MOUNTING AT COLLECTOR

The controller heat sensor is mounted to the nipple outlet of the collector (Figures 14). A stainless steel screw clamp should be used. The entire nipple should be wrapped thoroughly with insulating tape so that the sensor is isolated from the outside air.



Figure 14

10. PIPING THROUGH THE ROOF

Piping through the roof should be weatherproofed as shown in Figure 15.

- (a) One inch holes are drilled through the roof on the same plane as the supply and return header nipples. Do not drill the hole above the supply header of the collector. This will prevent the collector from draining. Placing the hole below the supply header is acceptable, but it is more aesthetic if it is located on the same plane
- (b) A copper flashing is placed around the hole with its base cemented to the roof and its upper edges slid under the adjoining shingle.
- (c) The copper tube supply and return line is then pushed up through the hole in the flashing. (d) A “coolie cap” is then slid over the copper tube till it meets the flashing. After piping to the collectors is completed, the “coolie cap” is soldered to the copper tube.
- (e) Polybutylene adhesive is then placed on the top and bottom of the flashing, providing a weatherproof seal. The sensor wire should also be run through the return flashing.

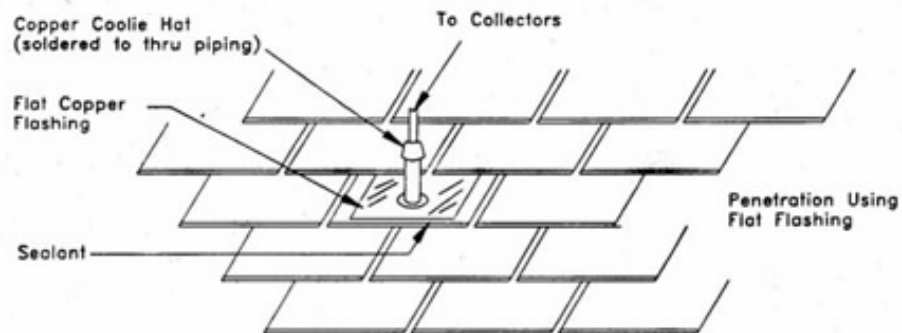

Figure 15

11. STORAGE TANK PLACEMENT

To minimize expense and heat loss, the tank should be placed near the collectors and central to points of greatest water demand. It should be located in as warm a spot as possible. It should be located with adequate ventilation, with a minimum of 6-8 inches of clearance and with ready access to controls and serviceable parts.

Provision should be made to prevent water damage in case of leakage. A catch pan with a minimum of $\frac{3}{4}$ " drain line at least 2" in height may be installed and pitched for proper drainage. Electrical service of 240V should be available for the element and 110V for the pump and controller.

12. SENSOR MOUNTING AT STORAGE TANK

On the open loop tanks the heat sensor is located behind the bottom front cover

Procedure:

- 1.) Remove the two screws that secure the bottom cover to the tank.
- 2.) Remove the fiberglass insulation until the shell of the tank is visible.
- 3.) Locate the 1/4" threaded stud and nut and the two sensor wires that were factory run from the top of the tank.
- 4.) Remove the 1/4" nut from the stud and place the 10 K sensors on the stud. Secure it with the nut.
- 5.) Attach the wires on the sensor to the factory run wires. Note: it does not matter which wire is attached to the other.
- 6.) Replace the insulation and bottom cover.

13. OPEN LOOP FLUID HANDLING SYSTEM

An open loop solar water heater operates by circulating water from the storage tank to the solar collectors when the collectors are at a higher temperature than the tank. This function is controlled by a differential temperature controller

with heat sensors. When the collectors are warmer than the water inside the tank, the controller switches on the pump. (Figure 16)

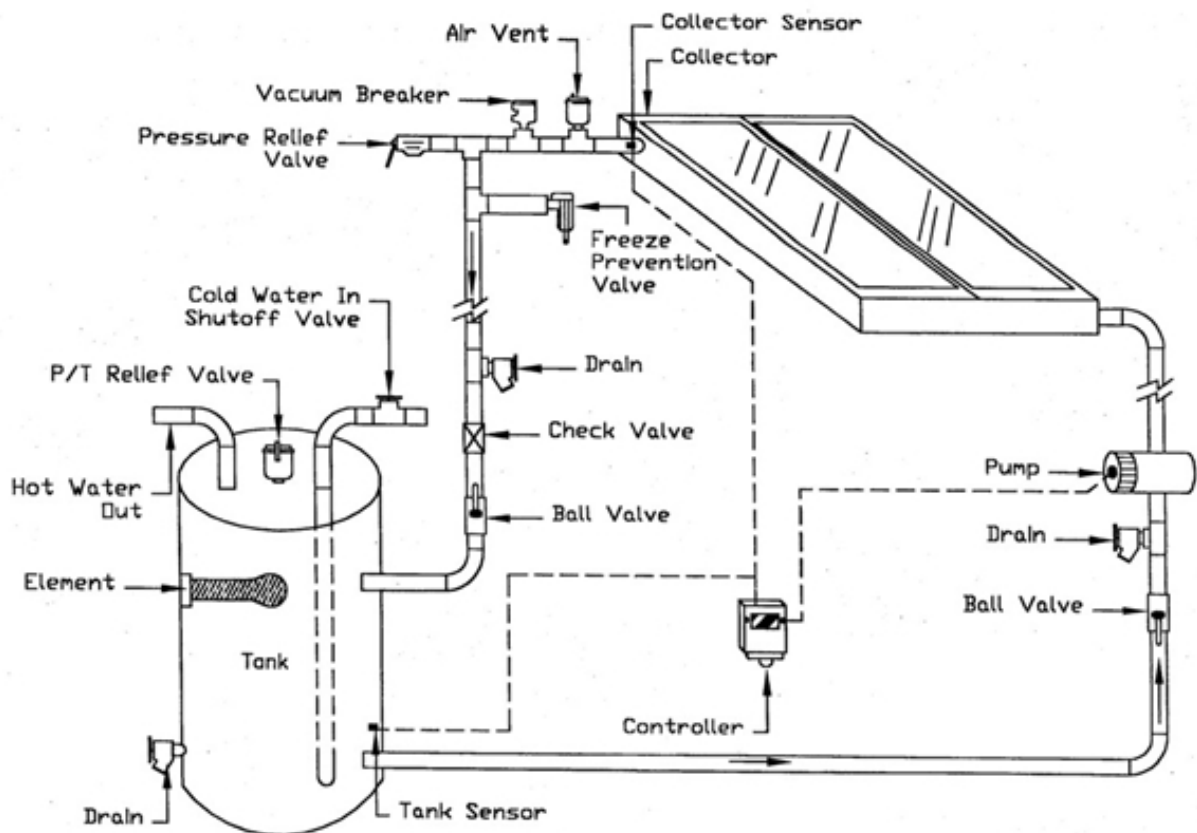

Figure 16

A re-circulation feature of the controller provides freeze protection. When the frost sensors at the collector indicate freezing temperatures, the pump is switched on and warm water is circulated through the collectors until warmed. The pump is then automatically switched off. This cycle repeats periodically until freezing conditions no longer exist. When a hard freeze is imminent or a power failure occurs, the system should be drained by closing the two gate valves that isolate the collector loop and opening the two valves that allow the collectors to drain.

Automatic air vents in the top of the system prevent

air locks. Care should be taken that no air can be trapped in piping to and from the collectors. Water returns to the tank from the collectors via a drop tuber that extends halfway down the interior of the tank. This allows the returning water to stratify properly.

A check valve in the return line from the collectors prevents thermo-siphon losses during the night. Temperature and pressure relief valves protect the system from damage.

A backup electric element is provided in the top of the tank to supply hot water during inclement weather. Power required is 240 volts.

14. OPEN LOOP DIFFERENTIAL TEMPERATURE CONTROLLER

NOTE: When instructions are provided in the controller package, follow those and disregard the following.

The open loop differential temperature controller controls the pump to gain maximum system efficiency. When one of the two heat sensors provided with the unit rises nominally 10°F above the other sensor, a power control relay is energized. Then, when the first sensor drops to within 5°F of the second sensor, the control relay remains energized holding its power contacts closed; however, when the temperature difference sensed is 5°F or less, the relay contacts open. (The 5°F value is designated as the "turn-off differential.") The first sensor is called the COLLECTOR SENSOR, since when properly installed monitors the temperature of Specifications:

OPERATING VOLTAGE

105 to 125 vac, 60 Hertz

CONTROL RELAY CONTACT RATING

One third HP inductive load.

TURN-ON DIFFERENTIAL

10°F (+1°F) for Storage Sensor at 135°F

TURN-OFF DIFFERENTIAL

5°F (+1°F) for Storage Sensor at 135°F

SENSOR MATCHING ACCURACY

1°F or less at 135°F

MAXIMUM SENSOR TEMPERATURE

300°F

the water in the solar collector. The second sensor is called the STORAGE SENSOR. The frost sensors activate the relay when freezing conditions exist. Mount the controller in any position or location that is convenient and sheltered from the elements. Aesthetics and economy of running power leads should dictate the location, since there is no restriction on the length of leads to the sensors. Connections to the circuit terminal strip inside the controller enclosure should be made according to Figure 17. ALL CONNECTIONS SHOULD BE MADE WITH ACCORDANCE WITH LOCAL ELECTRICAL CODES.

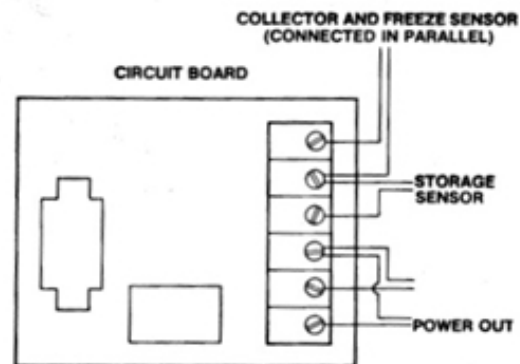

Figure 17

15. OPEN LOOP START-UP

After visual inspection of the complete system, it is ready for filling and pressure testing. All drain valves should be closed, all other valves opened. The air vent caps should be loosened two turns to allow air to escape the system. The cold water inlet valve should then be opened slowly and system checked for leaks as it fills. When the system is completely full, indicated by water escaping from the air vent when the valve is depressed it should be pressure checked with normal pressure for 30 minutes. Final inspection should then be made and power to the controller turned on. If the sun is shining and the storage tank is cool, the pump should come on and water should flow through the

collector. The first water through the collectors will be very hot but should stabilize in about 15 minutes. The return lines from the collectors should be hotter than the inlet lines and the collector glass should be slightly warmer than ambient temperature.

Testing of the frost sensor can be made at night when the pump is not normally working. A piece of ice set on the sensor should be sufficient to turn the pump on. The pump should turn off as soon as the sensor has a few seconds to warm back up when the ice is removed. Caution should be exercised when working on the roof at night.

16. OPEN LOOP MAINTENANCE

Maintenance of an open loop system is straightforward. The tank should be partially drained every 6 months to allow minerals to be removed preventing scale build up (this is recommended for all water heaters). The wye strainer should be cleaned at least once a year or more often if harsh water conditions exist. The

power should be switched off, the piping drained, and the screen removed and cleaned.

The collector glass should be kept clean for best system performance. Rainwater will usually suffice but a garden hose can be used during dry weather. The air vent caps should be loosened two turns for proper operation and best system performance.

17. DIRECT PV SYSTEM

The single photovoltaic module, attached to the top of the solar collector (Figure 18) operates a brushless 12 VAC or 24 VAC pump at a speed relative to the amount of available sun. When clouds pass over, the pumping operation slows to allow the water to remain in the collector longer for continued heating. When the sun goes down in the evening the pumping action will stop.

The solar system is installed as per the open loop installation manual. The photovoltaic module will replace the differential control and sensors. Be sure

to mount the panels on the same plane as the solar collector.

When wiring the photovoltaic module to the circulating pump use 16 gage stranded double exterior PVC jacketed wire for lengths up to 85 feet for 10 and 25 watt modules. Use 14 gage for over 85 feet for a module over 1.4 amps. When wiring the module to the pump remember that the black wire is always ground and the red wire is the hot wire. Do not reverse the polarity.

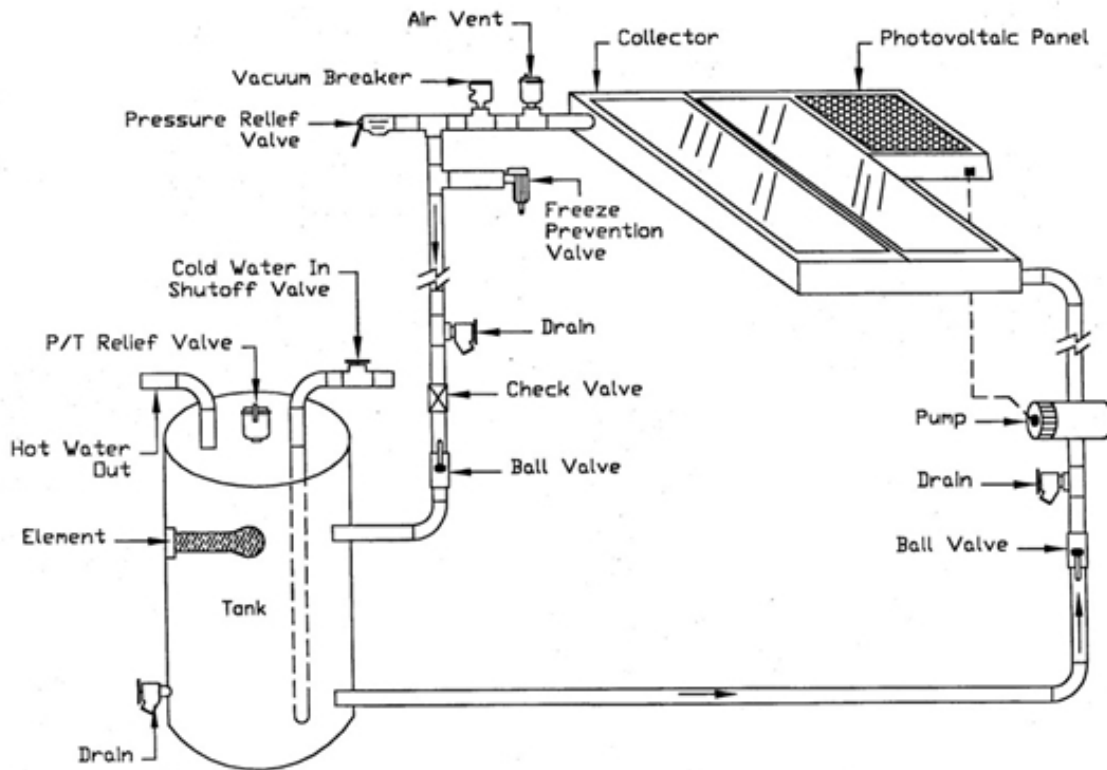

Figure 18

18. OPERATIONAL CHECKLIST

Before the system is turned on, the piping and electrical systems should be evaluated to see if they match the supplied drawings. If you are satisfied that the system is installed correctly, it should be filled and powered according to the preceding instructions. When the system is in the operational mode, care should be taken to check all piping for leaks and to make sure sufficient insulation has been used to provide maximum system efficiency. All modes of operation should be checked by the installer to assure proper functioning under all conditions.

TROUBLE SHOOTING GUIDE

Problems with systems usually fall under two categories: system leaks or lack of sufficient solar heated water.

LEAKS

If leaks exist the system should be shut down for repairs. Make sure the electrical circuit to the controller is off. Close off the cold water inlet or in case of a leak in the closed loop system, isolate as much of the system as possible and then drain and repair the affected area.

There is a possibility that what appears to be leaks may be condensation on the pipes. Also water escaping for the T & P valve may be an indication of proper function as they are designed to vent off excess temperature and pressure.

INSUFFICIENT HOT WATER

If insufficient hot water is available a system malfunction may not be indicated. A low amount of solar radiation or heavy water demand can be the cause.

If no excessive demands are put on the system and ample solar radiation is available, the system should operate properly. The pump should run each sunny day until a full supply of hot water is stored. If the pump does not run, there is a problem on the electrical end of the system. Either the pump,

controller, or sensors are malfunctioning. The controller can be bypassed by running a power cable directly to the pump and checking its function separate from the control system. Make sure that the problem is not a blown fuse or a tripped breaker. If the pump runs normally when powered externally, the control circuit is the problem area. Controllers use sensors to determine modes of operation. A controller test is available for checking differential function. Check sensor wiring. If no faulty wiring can be discovered, replace sensors.

If the pump is running all the time, even when the collectors are cool, then the storage sensor or collector sensor may be open. It is also possible that the sensor wire itself is at fault. To check this, test the continuity with an ohm meter. Be sure to disconnect the sensor when performing this test. Test the wire with both ends open, then retest often twisting the 2 sensor wires together at one end. The system can be set on a timer or switched on manually until the controller is properly functioning.

CONDENSATION ON COLLECTORS

If condensation occurs inside the collectors, ¼" vent holes should be drilled in the lower side of the collector. Three holes should be drilled, one at each end of the bottom of the collector and one in the center. These holes should be drilled 1" from the base of the collector

This should clear up any condensation within three days.

OTHER PROBLEMS

A noisy pump is an indication of worn bearings obstruction or loss of prime. As a rule of thumb about 8 to 12 degrees should be expected as a normal gain across a collector in bright sun at proper flow rate.

SYSTEM PARTS LIST

Solar Collectors
 Set of Mounting Hardware for each collector
 Hot Water Storage Tank
 Circulator Pump
 Pump Flanges
 Differential Temperature Controller
 Controller Sensors
 Fluid circulation components (valves and fittings)
 Installation Manual

COLLECTOR YARD MOUNT

When no sunny roof area is available or for “show” systems, the collectors can be mounted on the ground as shown in Figure 19. The piping and control wiring to the tank should be insulated and buried. It is important that the length of these piping runs be minimized.

Notes:

1. Front edge of collector should be 18” above ground
2. Use washers on all bolted wood connections
3. All pieces must be measured and cut to orient collector at latitude + 10° - consult trigonometric reference.
4. Piping to collector may be buried.

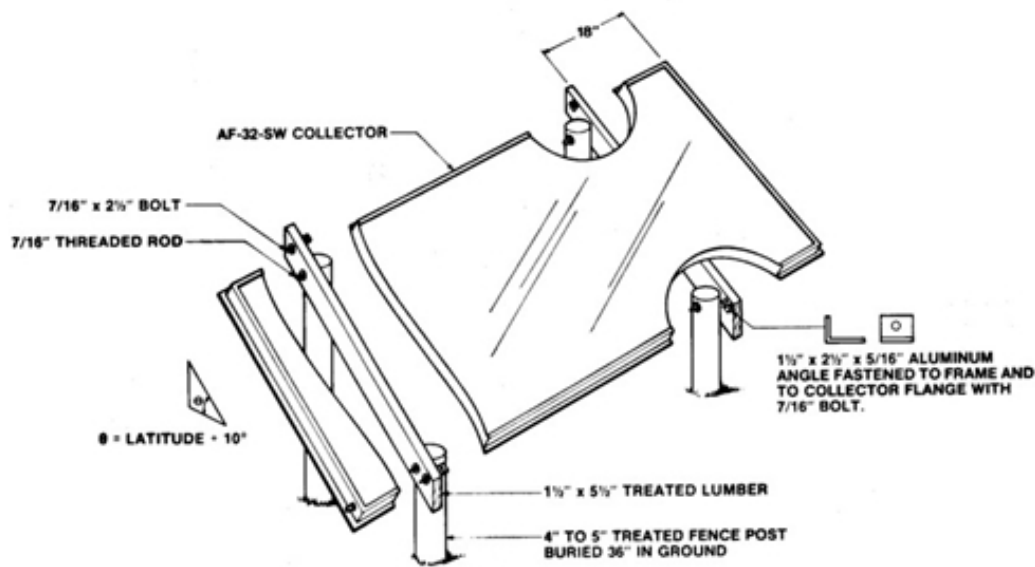

Figure 19